

## Dual power supply unit dNTA42

for primary voltages  
from 24 VAC to 230 VAC,  
intrinsically safe output voltage  
2 x 12 VDC

- Rugged pressure-proof housing, stainless steel for the safety-relevant closure elements
- Connection via plug-in socket
- Short-circuit-proof voltage output
- Light emitting diodes for the control of the output voltages
- Also available with integrated test switch
- Type of protection: IP44 acc. to EN 60529; EEx ia I intrinsically safe acc. to Directive 94/9/EC (ATEX)



*Dual power supply unit dNTA42  
for the supply of voltage to an  
electrohydraulic control unit*

## Function and design

The power supply unit includes two modules which each generate the 12V power. Both modules come integrated with all components required for converting the primary voltage into intrinsically safe output voltage. Thus, the two modules operate totally independent of each other which helps to essentially increase functional reliability. The voltage output is short circuit proof.

The modules are installed in a pressure-proof housing. The heat resulting from the power loss is dissipated thermally via the module housings and the pressure-proof housing.

## Application

The power supply unit is designed for supplying power to intrinsically safe equipment. It is available for input voltages of 24 VAC to 230 VAC at an output voltage of 12 VDC/ 0.6 A, 1 A, or 1.5 A each module.

Two pressure-proof cable entry glands are available for the mains power connection with one cable gland designed as lead-through to further power supply units. In order to permit a fast diagnosis if a fault occurs the power supply unit can be equipped with a test switch (see also the connection diagram with the test switch). The switch can be used to cut off the mains power to the downstream power supply units after an earth leakage occurred. At the same time, the monitoring conductor wired to terminal 6 is connected to earth potential via the diode/resistor combination. This arrangement permits to find out whether the power supply leading to this device is free from faults.

The intrinsically safe circuits are led out via plug-type connectors. For reasons of safety, the connection module with the plug connectors and the LEDs is fastened to the wall of the pressure-proof housing with cable entry glands and secured by cast resin so that it cannot be dismantled and the integrity of the pressure-proof chamber is maintained. Further connection to the consumers is effected using the SKK24 or SKK34 hoseline which has a proven track record in mining.

## Pin configuration

Mains connection		Intrinsically safe output	
without test switch	with test switch	Plug-in socket SKK24	Plug-in socket SKK34

## Technical data

Mains voltage	dNTA42A02412...	24 VAC ± 20 %
	dNTA42A03612...	36 VAC ± 20 %
	dNTA42A04212...	42 VAC ± 20 %
	dNTA42A11012...	110 VAC ± 20 %
	dNTA42A12712...	127 VAC ± 20 %
	dNTA42A23012...	230 VAC ± 15 %
Output voltage $U_o$		12,5 VDC
Output current $I_o$ each module	dNTA42A...1206.	0,65 A
	dNTA42A...1210.	1,05 A
	dNTA42A...1215.	1,55 A
Output socket	dNTA42A...12..A	SKK24
	dNTA42A...12..C	SKK34
Temperature range		-20 °C bis + 40 °C
Fitting position		any
Type of protection		IP 44 acc. to EN 60529/IEC 529; I M2 EEx d [ib] I acc. to Directive 94/9/EC
Certificate No		BVS 04 ATEX E 030

## Type code and ordering information

Type dNTA42A\*\*\*12\*\*\*

Connector:	A = SKK24; C = SKK34
Output current:	06 = 0,6 A; 10 = 1,0 A; 15 = 1,5 A
Mains voltage:	024; 036; 042; 110; 127; 230

## Typical example:

**dNTA42A2301215A**

Output connector	<b>SKK24</b>
Output current	<b>2 x 1,5 A</b>
Output voltage	<b>12 VDC</b>
Mains voltage	<b>230 VAC</b>

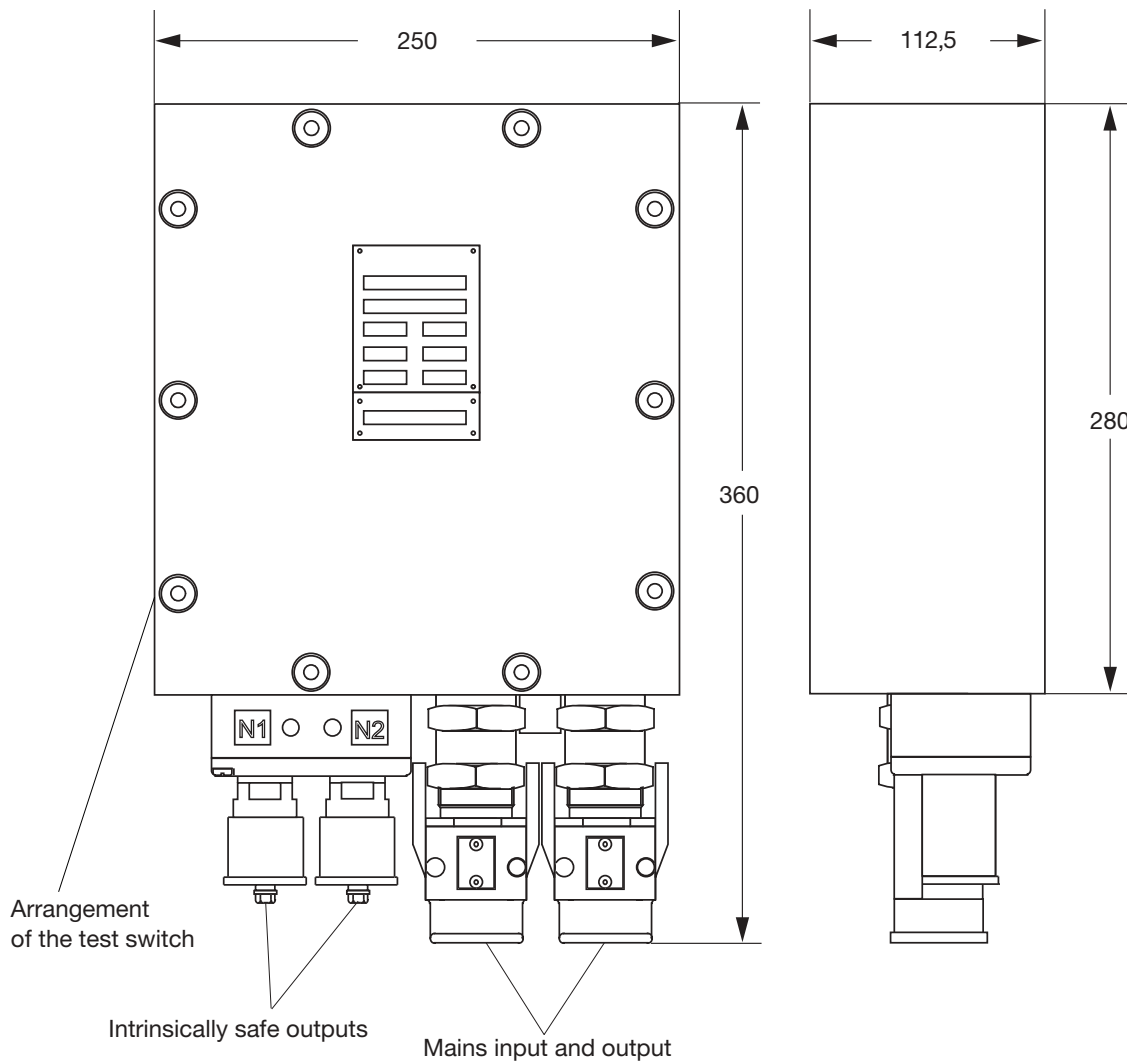

## Information for assembly

The hole pattern shown is located at the rear of the power supply unit. For fastening, the M10 threaded holes in the rear wall can be used.

The terminals for connection of the non-intrinsically safe mains circuit are accessible after the housing cover has been opened.

### Attention!

**Never operate the unit with the housing cover open. Operation is only allowed when the cover has been duly fitted and all cover bolts have been tightened.**

## Fastening - hole pattern

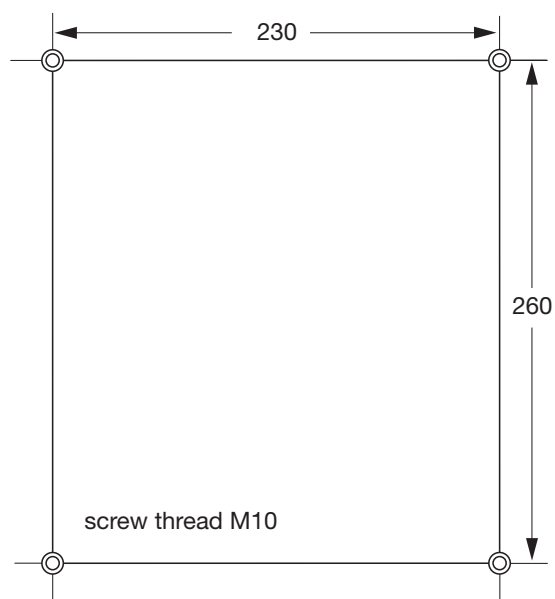



## Power supply unit **dNTA51**

for primary voltages  
from 24 VAC to 230 VAC,  
intrinsically safe output voltage  
12 VDC

- Rugged pressure-proof housing
- Connection via plug-in socket
- Short-circuit-proof voltage output
- Also available with integrated test switch
- Type of protection: IP 44 acc. to EN 60529; EEx ia I intrinsically safe acc. to Directive 94/9/EC (ATEX)



*Power supply unit dNTA51  
for the supply of voltage to a  
backflush filter station*

## Function and design

The power supply unit includes a module in which the 12V power is generated. This module comes integrated with all components required for converting the primary voltage into intrinsically safe output voltage. The voltage output is short circuit proof.

The module is installed in a pressure-proof housing. The heat resulting from the power loss is dissipated thermally via the module housing and the pressure-proof housing.

## Application

The power supply unit is designed for supplying power to intrinsically safe equipment. It is available for input voltages of 24 VAC to 230 VAC at an output voltage of 12 VDC / 0.6 A, 1 A, or 1.5 A.

Two pressure-proof cable entry glands are available for the mains power connection with one cable gland designed as lead-through to further power supply units. In order to permit a fast diagnosis if a fault occurs the power supply unit can be equipped with a test switch (see also the connection diagram with the test switch). The switch can be used to cut off the mains power to the downstream power supply units after an earth leakage occurred. At the same time, the monitoring conductor wired to terminal 6 is connected to earth potential via the diode/resistor combination. This arrangement permits to find out whether the power supply leading to this device is free from faults.

The intrinsically safe circuit is led out via a plug-in socket which has a pressure-proof screw connection to the power supply housing. Further connection to the consumers is effected using the SKK24 hoseline which has a proven track record in mining.

## Pin configuration

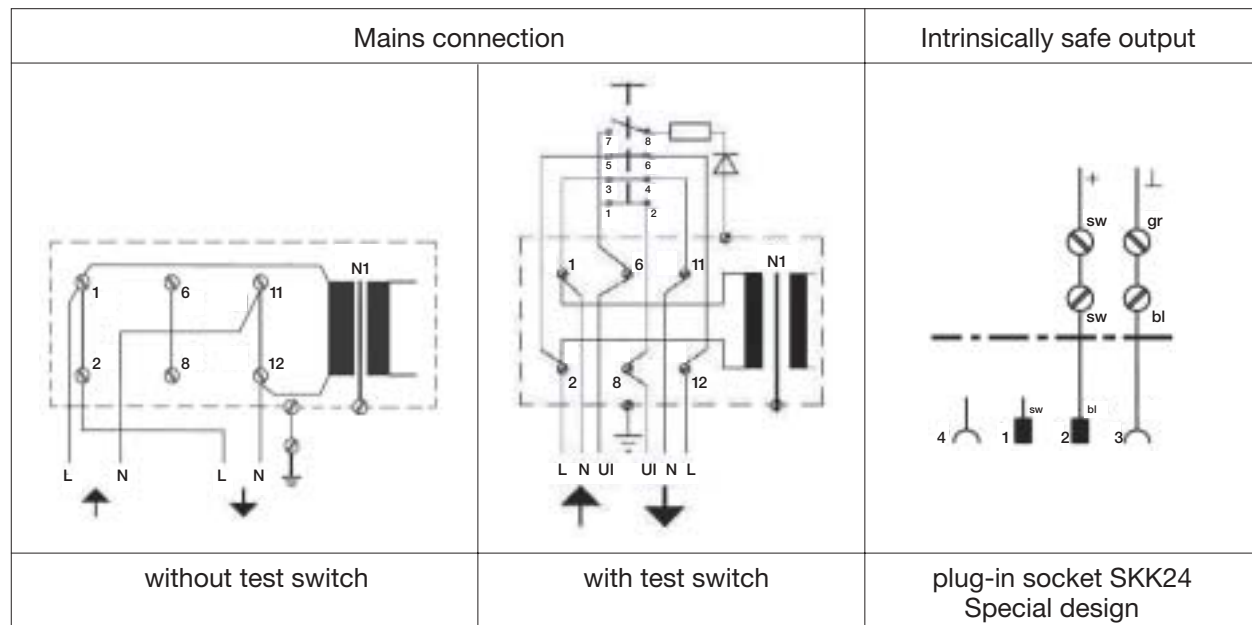

## Technical data

Mains voltage	dNTA51A02412...	24 VAC ± 20 %
	dNTA51A03612...	36 VAC ± 20 %
	dNTA51A04212...	42 VAC ± 20 %
	dNTA51A11012...	110 VAC ± 20 %
	dNTA51A12712...	127 VAC ± 20 %
	dNTA51A23012...	230 VAC ± 15 %
Output voltage U <sub>o</sub>		12,5 VDC
Output current I <sub>o</sub> each module	dNTA51A...1206.	0,65 A
	dNTA51A...1210.	1,05 A
	dNTA51A...1215.	1,55 A
Output socket	dNTA51A...12..A	SKK24
Temperature range		-20 °C to + 40 °C
Fitting position		any
Type of protection		IP 44 acc. to EN 60529/IEC 529; I M2 EEx d [ib] I acc. to Directive 94/9/EC
Certificate No.		BVS 04 ATEX E 035

## Type code and ordering information

Type dNTA51A\*\*\*12\*\*\*

Connector:	A = SKK24
Output current:	06 = 0,6 A; 10 = 1,0 A; 15 = 1,5 A
Mains voltage:	024; 036; 042; 110; 127; 230

## Typical example:

dNTA51A0421215A

Output socket	<b>SKK24</b>
Output current	<b>1,5 A</b>
Output voltage	<b>12 VDC</b>
Mains voltage	<b>42 VAC</b>

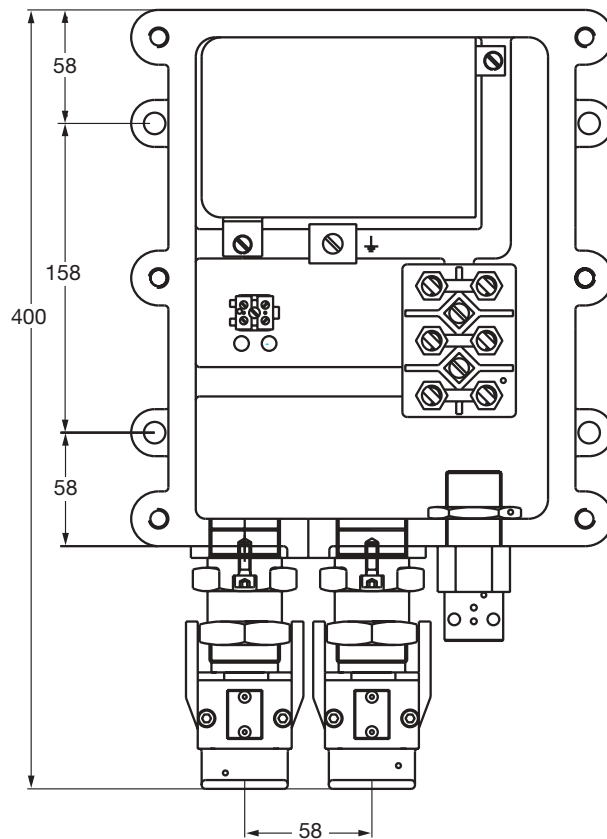
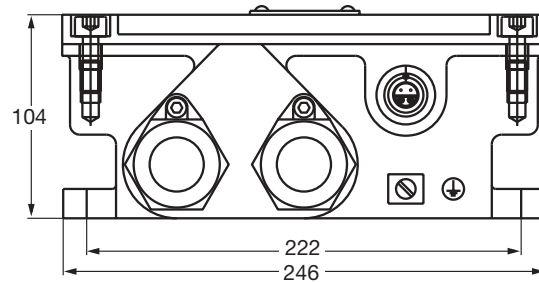

### Information for assembly

The terminals for connection of the non-intrinsincally safe mains circuit are accessible after the housing cover has been opened.

### Attention!

**Never operate the unit with the housing cover open. Operation is only allowed when the cover has been duly fitted and all cover bolts have been tightened.**