

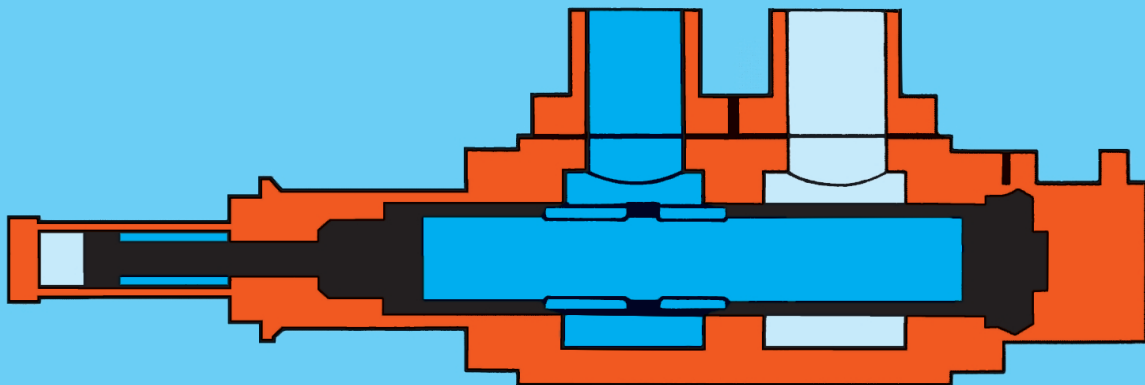

Reserveteile für Kolbenschieber
Piston Valves Spare Parts
Vannes à piston pièces de rechange

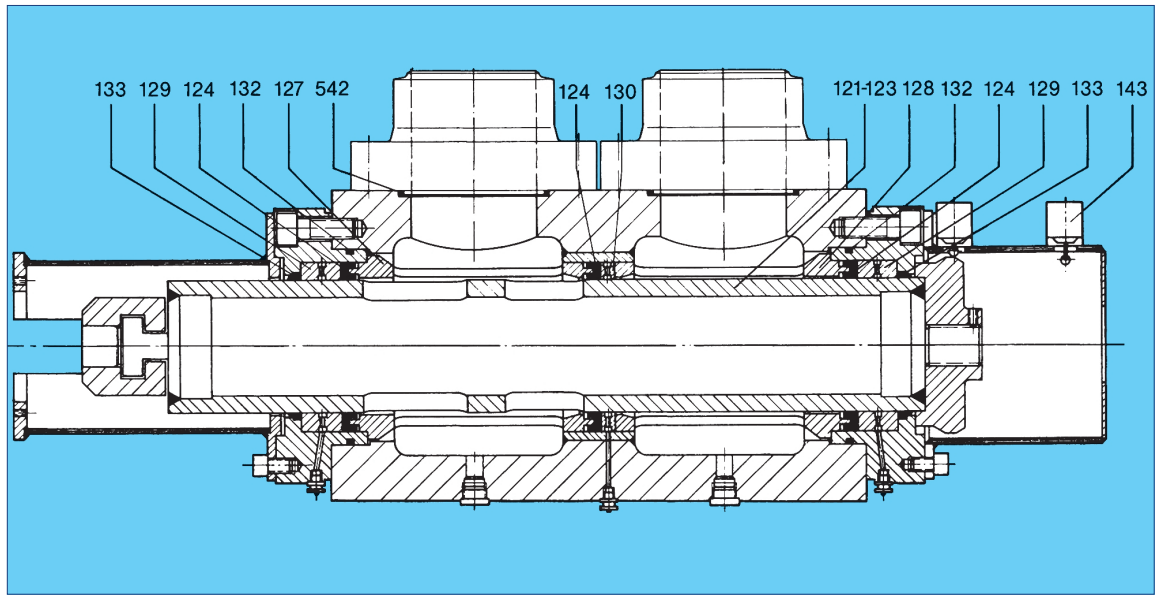

Kolbenschieber
Piston valve
Vanne à piston



Kolbenschieber Piston valve Vanne à piston										
Teil	Kolben	Manschette	Halte- büchse	Halte- büchse	Stützring	Stützring	O-Ring	Abstreifer	Endschalter	Dichtung
Parts	Piston	Packing	Bushing	Bushing	Supporting- ring	Supporting- ring	"O"ring	Wiper	Limit switch	Seal
Pièces	Piston	Manchette	Douille d'arrêt	Douille d'arrêt	Bague d'appui	Bague d'appui	Joint torique	Racleur	Fin de course	Joint
DN	121-123	124	127	128	129	130	132	133	143	542
80	80 121-123	80 124	80 127	80 128	80 129	80 130	80 132	80 133	80 143	80 542
100	100 121-123	100 124	100 127	100 128	100 129	100 130	100 132	100 133	100 143	100 542
125	125 121-123	125 124	125 127	125 128	125 129	125 130	125 132	125 133	125 143	125 542
150	150 121-123	150 124	150 127	150 128	150 129	150 130	150 132	150 133	150 143	150 542
200	200 121-123	200 124	200 127	200 128	200 129	200 130	200 132	200 133	200 143	200 542
250	250 121-123	250 124	250 127	250 128	250 129	250 130	250 132	250 133	250 143	250 542

Luftvorsteuerung
Air-operated pilot cylinder
Pilotage par l'air

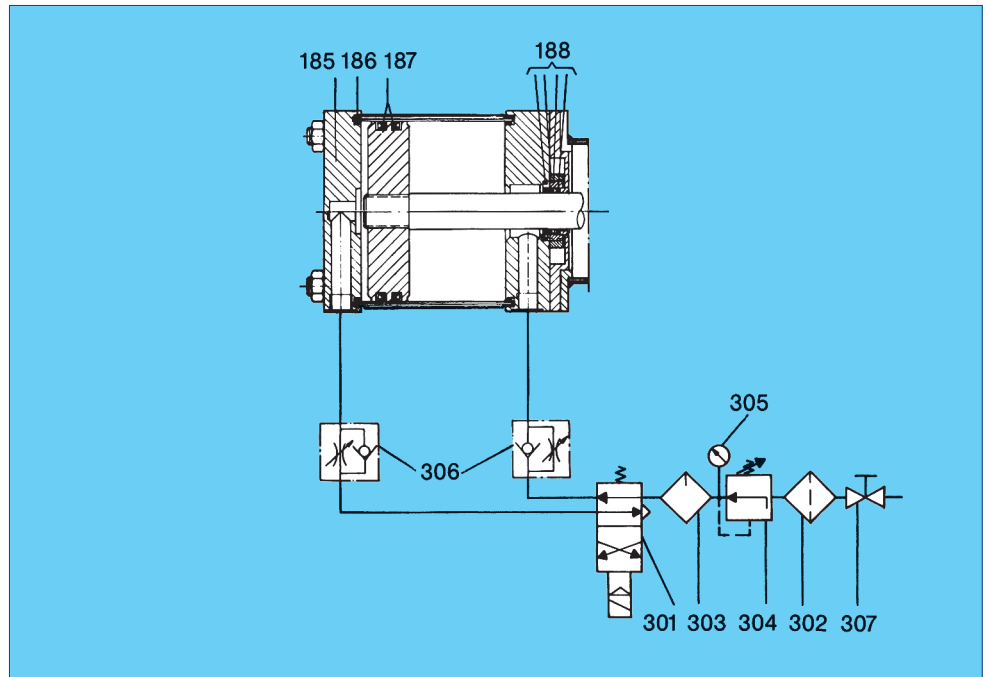

	Vorsteuerzylinder Pilot control cylinder Cylindre pilote				Steuerelemente Control elements Organes de distribution						
Teil Parts Pièces	Vorsteuerzylinder Pilot control cylinder Cylindre pilote	Zylinderdichtungssatz Cylinder seal set Jeu de joints de cylindre	Kolbendichtungssatz Piston seal set Jeu de joints de piston	Kolbenstangendichtungssatz Piston rod seal set Jeu de joints de bielle	Magnetventil Solenoid valve Électrovanne	Filter Filter Filtre	Öler Lubricator Huileur	Druckminderer Regulator Détendeur	Manometer Pressure gauge Manomètre	Drosselrückschlagventil Combined throttle check valve Soupape de retenue et d'étranglement	Absperrventil Shut-off valve Vanne de sectionnement
DN	185	186	187	188	301	302	303	304	305	306	307
80	80 185	80 186	80 187	80 188	80 301	80 302	80 303	80 304	80 305	80 306	80 307
100	100 185	100 186	100 187	100 188	100 301	100 302	100 303	100 304	100 305	100 306	100 307
125	125 185	125 186	125 187	125 188	125 301	125 302	125 303	125 304	125 305	125 306	125 307
150	150 185	150 186	150 187	150 188	150 301	150 302	150 303	150 304	150 305	150 306	150 307
200	200 185	200 186	200 187	200 188	200 301	200 302	200 303	200 304	200 305	200 306	200 307
250	250 185	250 186	250 187	250 188	250 301	250 302	250 303	250 304	250 305	250 306	250 307



Wasser- und Ölvorsteuerung
Water- and oil-operated
pilot cylinder
Pilotage
par l'eau l'huile

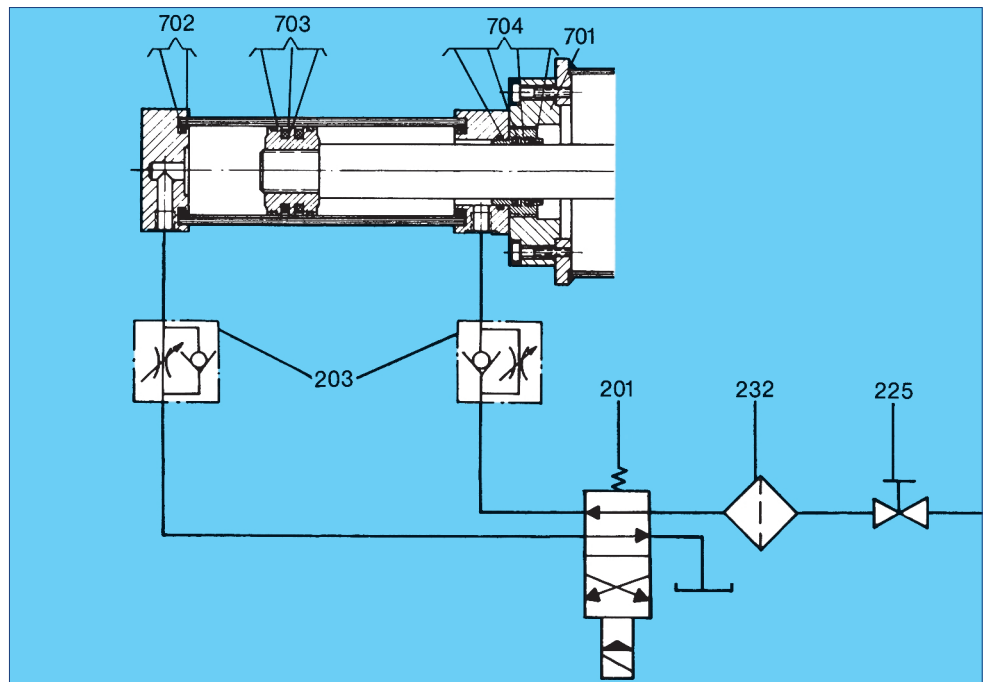

Vorsteuerzylinder Pilot control cylinder Cylindre pilote					Steuerelemente Control elements Organes de distribution			
Teil Parts Pièces	Vorsteuer- zylinder Pilot control cylinder Cylindre pilote	Zylinder- dichtungssatz Cylinder seal set Jeu de joints de cylindre	Kolben- dichtungssatz Piston seal set Jeu de joints de piston	Kolbenstangen- dichtungssatz Piston rod seal set Jeu de joints de bielle	Magnetventil Solenoid valve Électrovanne	Filter Filter Filtre	Drosselrück- schlagventil Combined throttle check valve Soupape de retenue et d'étranglement	Absperrventil Shut-off valve Vanne de sectionnement
DN	701	702	703	704	201	232	203	225
80	80 701	80 702	80 703	80 704	80 201	80 232	80 203	80 225
100	100 701	100 702	100 703	100 704	100 201	100 232	100 203	100 225
125	125 701	125 702	125 703	125 704	125 201	125 232	125 203	125 225
150	150 701	150 702	150 703	150 704	150 201	150 232	150 203	150 225
200	200 701	200 702	200 703	200 704	200 201	200 232	200 203	200 225
250	250 701	250 702	250 703	250 704	250 201	250 232	250 203	250 225